

MEMORY

In the Grammar Stage

HOW DO WE REMEMBER?



I REMEMBER



...the days of old;

I meditate on all that you have done;

I ponder the work of your hands.

I stretch out my hands to you;

my soul thirsts for you like a parched land.

Psalm 143:5-6

REMEMBER THEIR FRAME

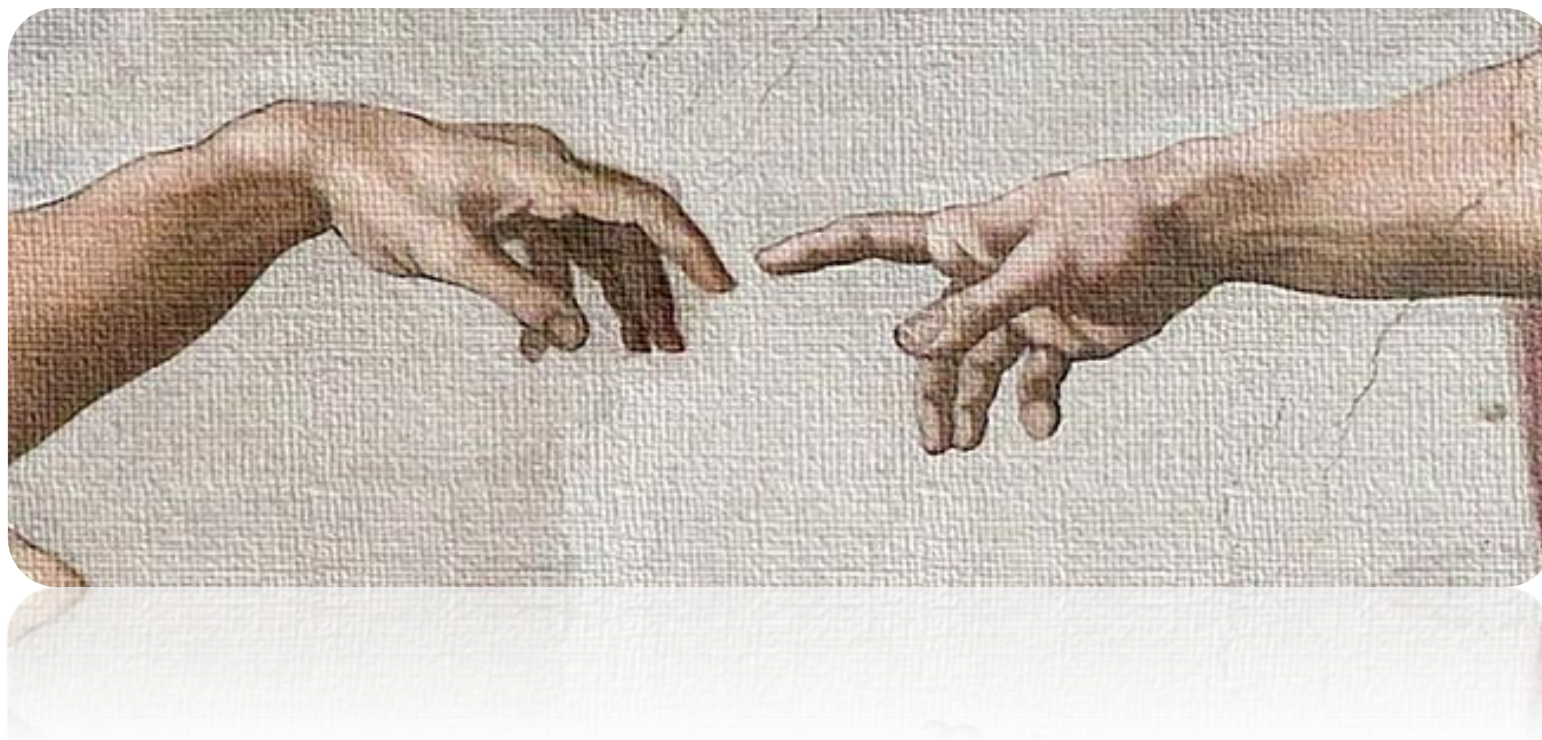

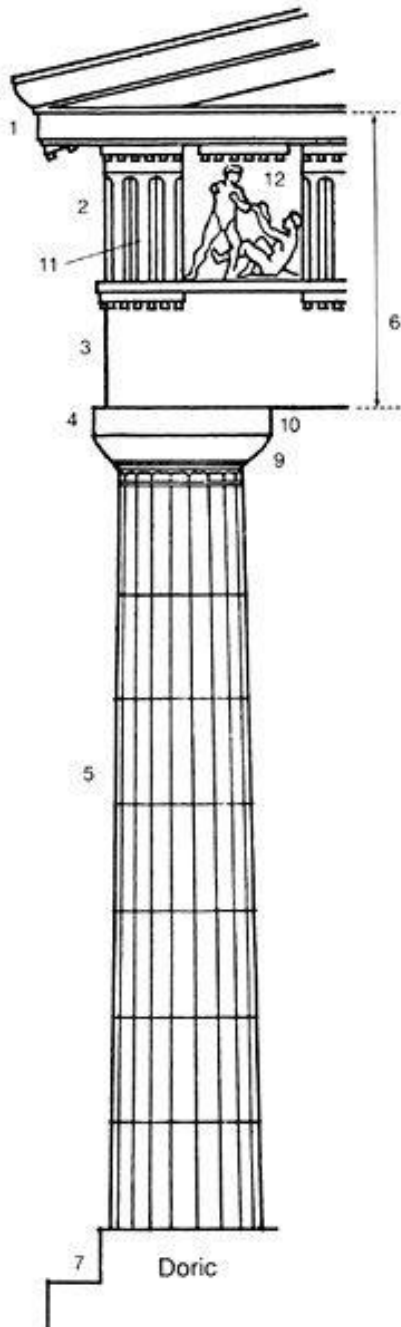

Doric

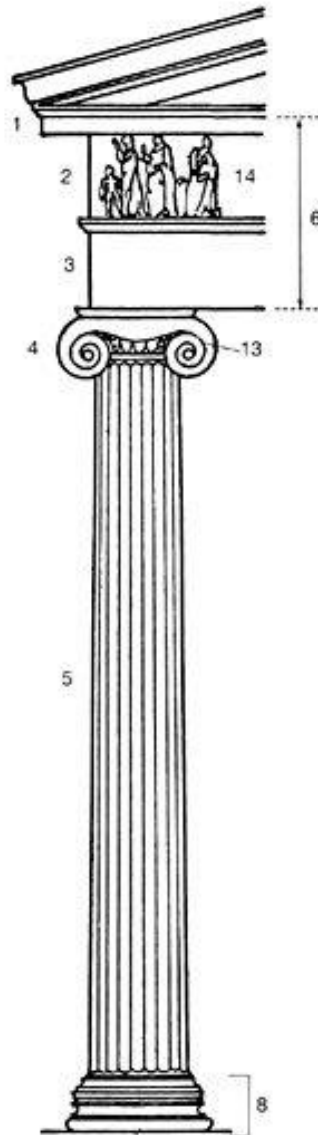

Ionic

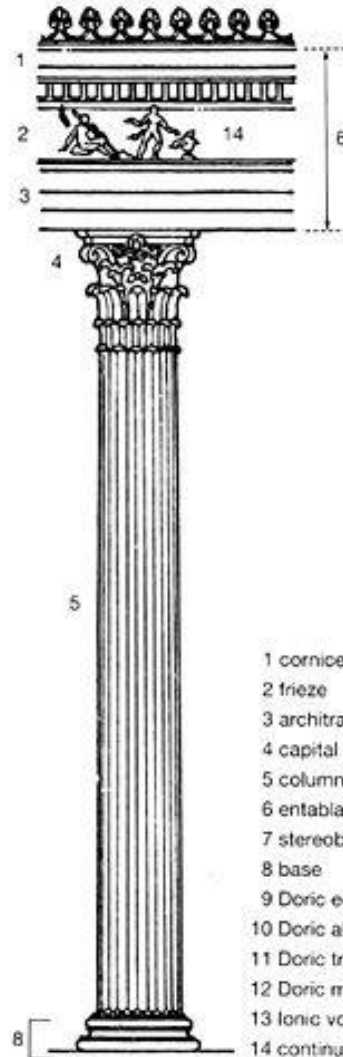

Corinthian

- 1 cornice
- 2 frieze
- 3 architrave
- 4 capital
- 5 column
- 6 entablature
- 7 stereobate
- 8 base
- 9 Doric echinus
- 10 Doric abacus
- 11 Doric triglyph
- 12 Doric metope
- 13 Ionic volute
- 14 continuous frieze

TOOLS IN THE TOOLBOX



CHANTS



- ❖ Frontload information
- ❖ Provide context for connection
 - ❖ Provide structure
 - ❖ Train students to focus
 - ❖ Train students to follow
 - ❖ Train students to lead
- ❖ Cultivate wonder and awe

The History of Israel

Covenant Academy

Cypress, TX

(Each dash is a clap or bang on the desk.)

| | | | | | |
|-------------------------|----|---------------------|----|--------|----|
| 1. The Patriarchs | -- | 2200–1700 BC | -- | | |
| 2. Slavery in Egypt | -- | 1700–1453 BC | -- | | |
| 3. The Exodus | -- | 1453 BC | -- | | |
| 4. Judges | -- | 1413–1020 BC | -- | | |
| 5. The United Kingdom | -- | 1051–931 BC | -- | | |
| 6. Solomon's Temple | -- | 960 BC | -- | | |
| 7. Divided Kingdom | -- | 930 BC | -- | | |
| 8. The Babylonian Exile | -- | 605–535 BC | -- | | |
| 9. Assyrian Exile | -- | 722–720 BC | -- | | |
| 10. Return & Rebuilding | -- | 536–415 BC | -- | | |
| 11. Conquering | -- | Alexander the Great | -- | 332 BC | -- |
| 12. Roman Rule | -- | 63 | -- | BC | -- |
| 13. Jesus Christ | -- | in 3 | -- | AD | -- |

EXPERIENCES AND EXPLANATIONS



❖ Stories

❖ Activities

❖ Fieldtrips

❖ Museums

❖ Plays

❖ Projects

CAVEATS



RULES
without
RELATIONSHIPS
lead to
REBELLION

JOSH MCDOWELL



IMITATING OUR CREATOR.

Love that builds trust.

❖ Enter

❖ Eyes

❖ Touch

❖ Voice

❖ Boundaries

A close-up photograph of a person's hands holding a small, vibrant green seedling with three leaves. The seedling is growing out of a mound of dark, rich soil held in the palms. The background is softly blurred, showing more of the hands and a hint of a green environment.

PREPARE THE SOIL

for transformation.

Aim at the heart.

KNOW THYSELF.

What rules you?

❖ Success

❖ Approval

❖ Appreciation

❖ Pleasure/Comfort

❖ Control

OUR GOAL



Wisdom and Virtue

ARISTOTLE



Habit brings
virtue to
completion.

YOU GET MORE OF WHAT YOU SUBSIDIZE AND LESS OF WHAT YOU PENALIZE.



Teach kids to economize.

- Skills that build up others
- Teach approximations of skills toward fuller skillsets

- Skills that burden others
- Allow avoidance of skills toward lower expectation.

| | |
|---------|--------|
| Empower | Equip |
| Enable | Excuse |

- Feel: Able
- Seek to help others
- Build more skills

- Feel: Afraid
- Seek help from others
- Need more help

Questions?



leslie.collins@covenantcypress.org